



Tunnel - 5' Wide x 3' High

Advance Concrete Products Company

info@advanceconcreteproducts.com



248-887-4173

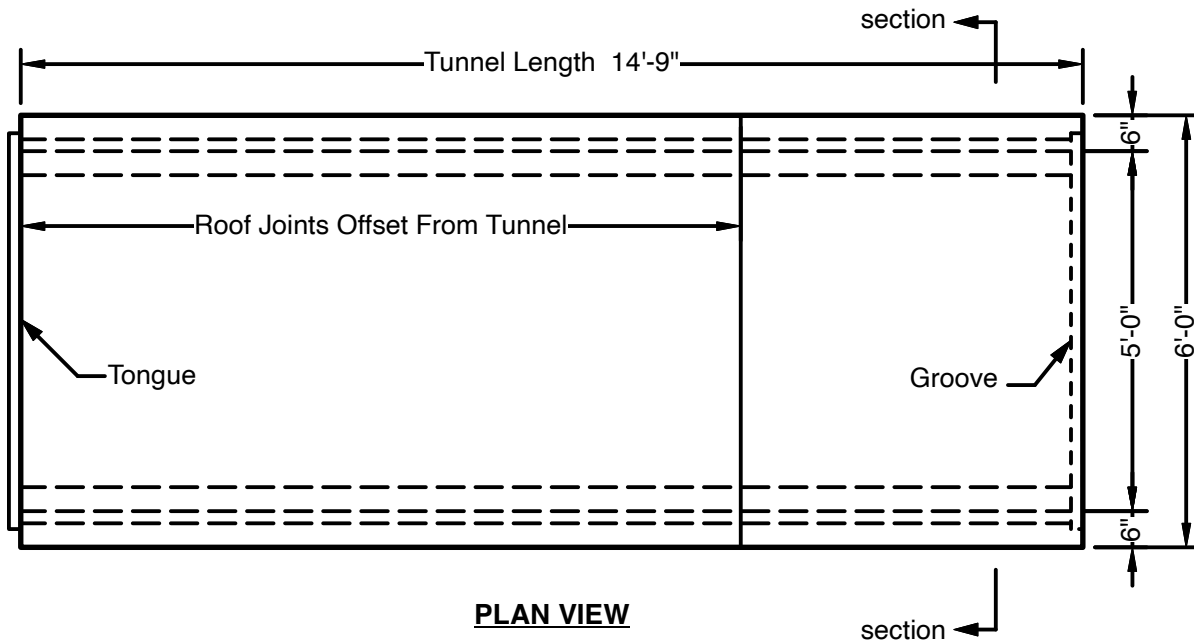

PLAN VIEW

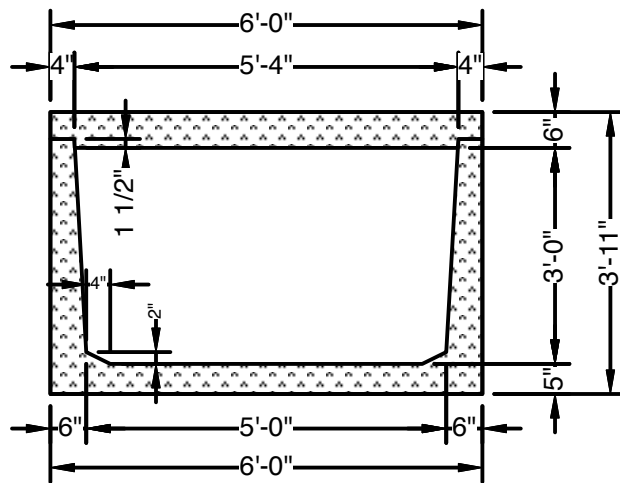

SECTION VIEW
Showing Removable Roof

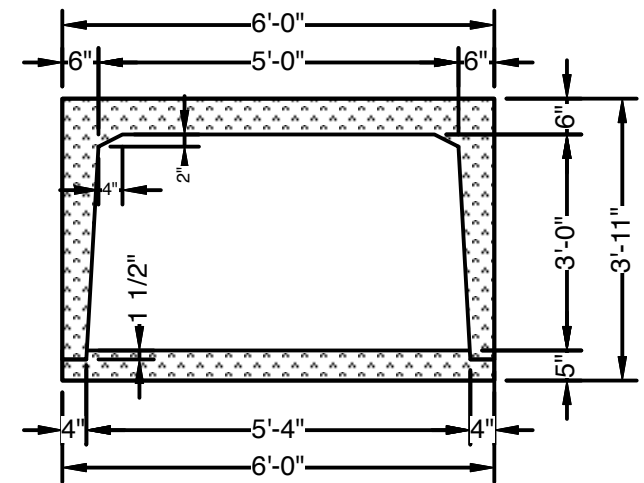

SECTION VIEW
Showing Keyed Floor Slab

All Concrete Shall Have A 28 Day Compressive Strength Of 4500 PSI.

Reinforcing Steel Shall Comply With ASTM A615 Grade 60 Rebar.
Bar Bending And Placement Shall Comply With The Latest ACI Standards.

Standard Structural Design Based On AASHTO HS 20 Wheel Loading
with 12" to 36" cover.

1" Ø CS-102 Butyl Rope Mastic Is Provided For Placement
Between Each Section.

This Drawing Shows A Sample.
We Can Manufacture Tunnels To Meet Your Requirements.

- Available Options -
- Varying Lengths & Heights
- Embedded Steel Plates Or Strut Inserts
- Aluminum Access Hatches
- Cast Iron Frames & Covers
- Custom Opening Locations
- Epoxy Coated Rebar Reinforcement
- Composite Rebar Reinforcement