

BILL OF MATERIAL

ITEM NUMBER	CATALOG NUMBER	DESCRIPTION	QUANTITY REQUIRED
①	FSRM-12	1/2"-13 DROP-IN ANCHOR Material: 18-8 STAINLESS STEEL	3
②	FFW316-18-40	FLAT WASHER ID=.562, OD=1.250, THK=.078 Material: 316 STAINLESS STEEL	3
③	FHC316-16-044	1/2"-13 X 1-3/8" LG. HEX HEAD CAP SCREW Material: 316 STAINLESS STEEL	3
④	CR20-B	CR20-B STANCHION Material: 50% Glass Reinforced Nylon	1
⑤	RA14	RA14 ARM (14" LONG) Material: 50% Glass Reinforced Nylon	1
⑥	RA20	RA20 ARM (20" LONG) Material: 50% Glass Reinforced Nylon	1
⑦	HDL	HDL LOCK (OPTIONAL) Material: Polycarbonate	1 PER ARM
NOT SHOWN	FRT-112	SETTING TOOL (Used to install Catalog No. FSRM-12 Drop-In Anchor)	AS REQ'D

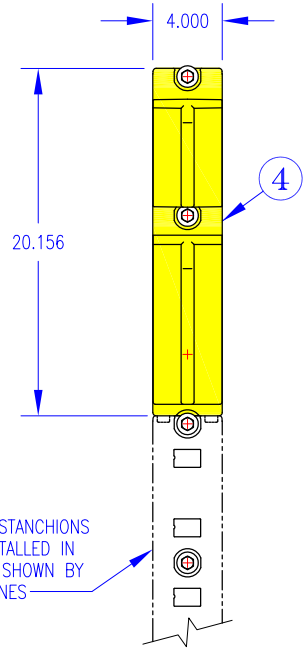
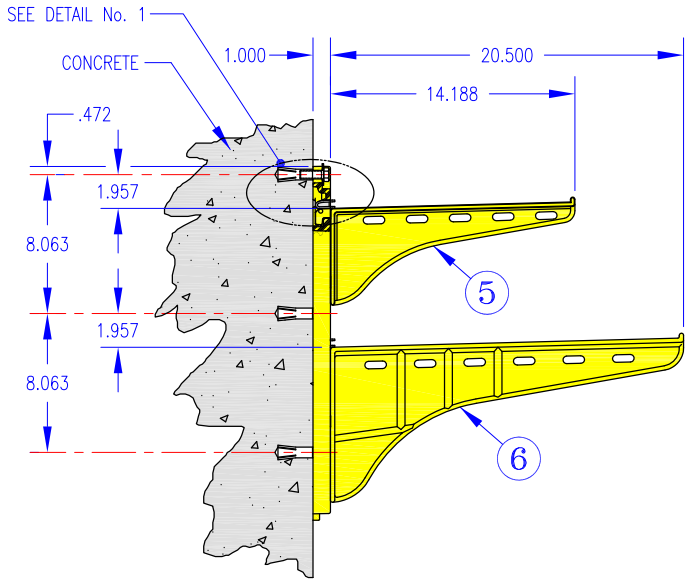

GENERAL INSTALLATION GUIDELINES

- BE SURE THE SURFACE OF THE CONCRETE WALL IS SMOOTH, FLAT AND PLUMB.
- IT IS IMPERATIVE TO INSTALL A FASTENER SET IN EVERY ELONGATED STANCHION HOLE.**
- INSTALL EACH DROP-IN ANCHOR AS SHOWN ON THIS DRAWING AND AS DESCRIBED BELOW:
 - DRILL A 5/8" DIAMETER HOLE 2" DEEP.
 - BLOW OUT HOLE.
 - DRIVE ANCHOR FLUSH TO 1/16" BELOW SURFACE OF CONCRETE.
 - EXPAND ANCHOR WITH FRT-112 SETTING TOOL. ANCHOR IS PROPERLY SET WHEN SHOULDER OF SETTING TOOL IS FLUSH WITH THE TOP OF ANCHOR.
- INSTALL THE FLAT WASHER AND TIGHTEN THE CAP SCREW JUST ENOUGH TO ATTAIN A SNUG FIT. AVOID HIGH SCREW TORQUE WHICH INDUCES COMPRESSIVE STRESS.
- AFTER ASSEMBLING THE ARMS TO THE STANCHION, TAP THE ARM DOWN WITH A LIGHT MALLET BLOW. THE LIGHT MALLET BLOW WILL FULLY SEAT AND LOCK ARM IN PLACE.
- INSTALL OPTIONAL HDL LOCK BY PLACING THE LOCK ON THE ARM WITH THE LOCKING BARBS UP. PUSH THE LOCK INTO THE RECTANGULAR HOLE IN THE STANCHION. WHEN THE STOP FLANGES ON THE LOCK HIT THE STANCHION, THE LOCK WILL CLICK INTO PLACE. SEE DETAIL No.1 AT LEFT.

NOTES:

- THE ANCHOR ARRANGEMENT SHOWN ON THIS INSTALLATION DRAWING ALLOWS FOR COMPLETE VARIABILITY OF ARM SIZE & LOCATION OF ARM ON STANCHION.
- SEE UDI "MOUNTING HARDWARE" CATALOG SHEET (FORM 120292AD) FOR ANCHOR LOAD CAPACITY, GENERAL ANCHOR NOTES AND HEX HEAD CAP SCREW NOTES.
- SEE UDI "TECHNICAL DATA" CATALOG SHEET (FORM 111391AE) FOR LOAD CARRYING CAPACITY.
- SEE UDI "GUIDE SPECIFICATION" (FORM 123191AK) FOR GENERAL SPECIFICATIONS ON THE HEAVY DUTY NON-METALLIC CABLE RACK.

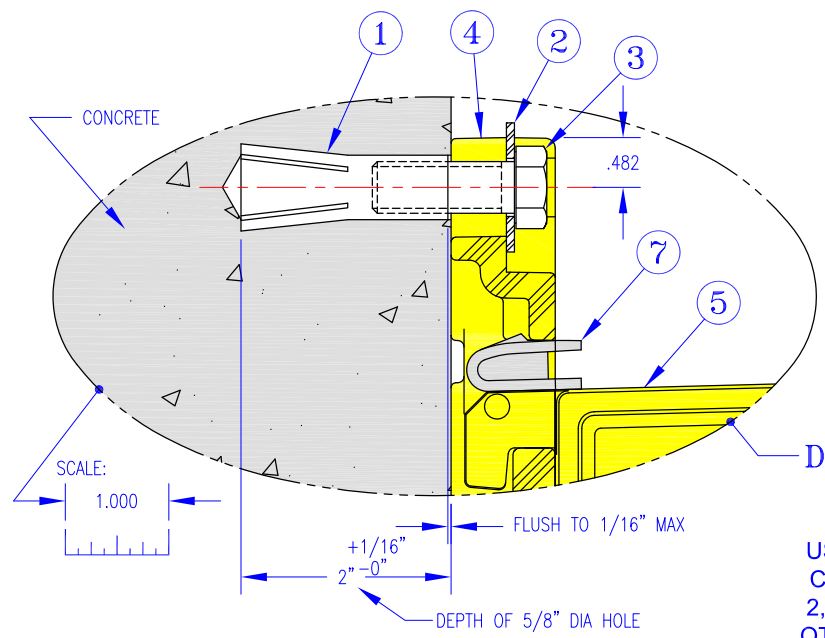

DETAIL No.1

US PATENT 7,140,500
CANADIAN PATENTS
2,486,904 & 2,640,899.
OTHER PATENTS MAY
APPLY OR BE PENDING.



HEAVY DUTY NON-METALLIC CABLE RACK Installation Details For 1 Ea. CR20-B Stanchion With 1 Ea. RA14 & 1 Ea. RA20 Arm Using Drop-In Anchors

SCALE: See At Left	DESIGNED BY: Don McCoy	DRAWN BY: Alan Armstrong	CHECKED BY: Don McCoy
DATE: 12-16-03	APPROVED BY:		REVISION F 10-3-18

1st Designed For TYPICAL INSTALLATION OF CABLE RACKS

UNDERGROUND DEVICES, INC. DRAWING NUMBER: 90-3174
NORTHBROOK, ILLINOIS 60062 - PHONE: (847) 205-9000 PAGE 1 OF 1