



5' x 5' x 4' Handhole

Advance Concrete Products Company



(800) 824-8351 (248) 887-4173 Fax: (248) 887-2755

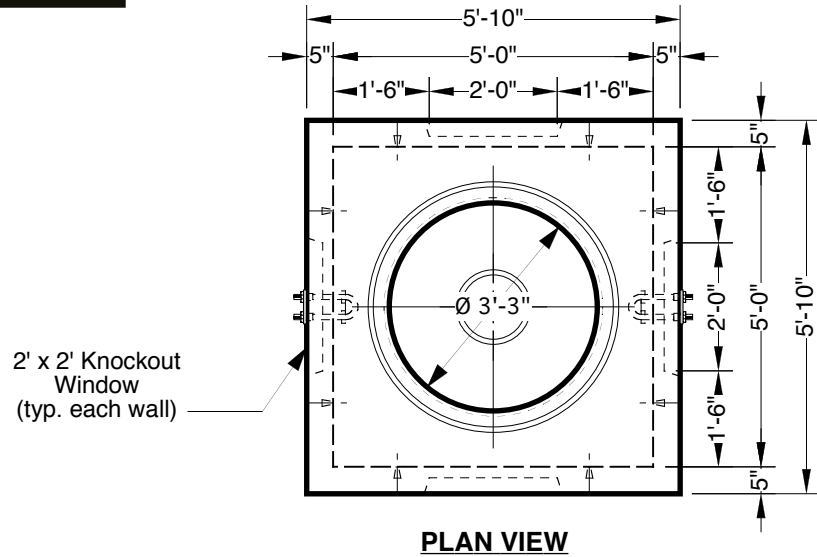

All Concrete Shall Have A 28 Day Compressive Strength Of 4500 PSI.

Reinforcing Steel Shall Comply With ASTM A615 Grade 60 Rebar.
Bar Bending And Placement Shall Comply With The Latest ACI Standards.

Standard Structural Design Based On AASHTO HS 20 Wheel Loading.

1" Ø Butyl Rubber Rope Mastic Is Provided For Placement In Top Seam.

- Options -
- Cast Iron Heavy Duty Frames & Covers
 - Galvanized Steel Hardware
 - 6", 12" And 24" High Grade Adjustment Rings
 - Custom Openings

Approximate Weight Total: ± 9,500 Lbs.
Bottom Section : ± 7,500 Lbs. Roof: ± 2,000 Lbs.

* Please allow for 1/2" height differential depending on air temperature affecting viscosity of Ø1" rope mastic between roof and walls.

