

4' x 4' x 4' Standard Knockout Handhole

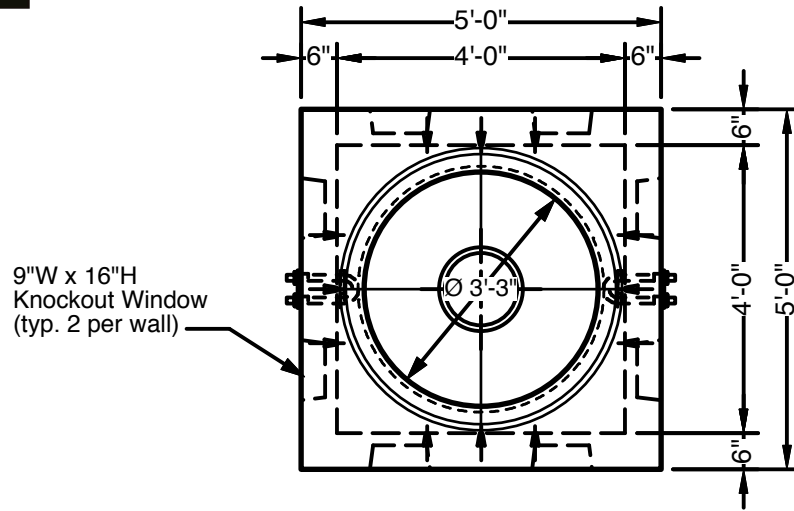

Advance Concrete Products Company

(800) 824-8351 (248) 887-4173 Fax: (248) 887-2755



PLAN VIEW

All Concrete Shall Have A 28 Day Compressive Strength Of 4500 PSI.

Reinforcing Steel Shall Comply With ASTM A615 Grade 60 Rebar.
Bar Bending And Placement Shall Comply With The Latest ACI Standards.

Standard Structural Design Based On AASHTO HS 20 Wheel Loading.

1" Ø CS-102 Butyl Rope Mastic Is Provided
For Placement In Top Seam.

Approximate Weight Total: ± 8,500 Lbs.
Bottom Section : ± 7,200 Lbs. Roof: ± 1,300 Lbs.

* Please allow for 1/2" height differential depending on air temperature affecting viscosity of Ø1" rope mastic between roof and walls.

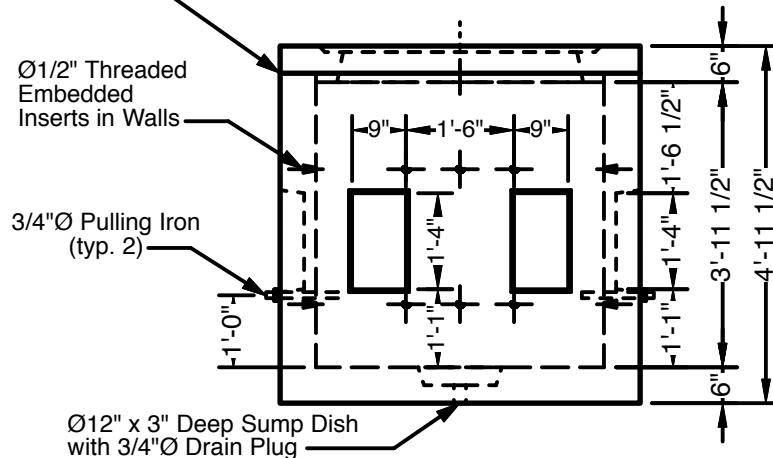

SIDE VIEW

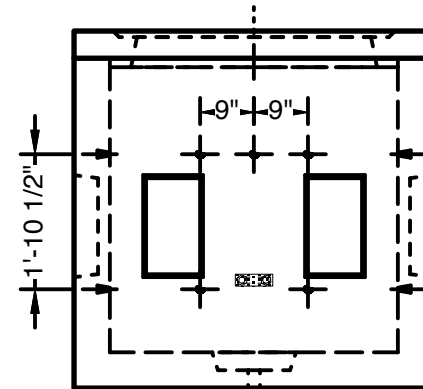

END VIEW