

Tunnel - 4' Wide x 3' High

Advance Concrete Products Company



(800) 824-8351 (248) 887-4173 Fax: (248) 887-2755

All Concrete Shall Have A 28 Day Compressive Strength Of 4500 PSI.

Reinforcing Steel Shall Comply With ASTM A615 Grade 60 Rebar.
Bar Bending And Placement Shall Comply With The Latest ACI Standards.

Standard Structural Design Based On AASHTO HS 20 Wheel Loading.

1" Ø Butyl Rubber Rope Mastic Is Provided For Placement
Between Each Section.

This Drawing Shows A Sample.
We Can Manufacture Tunnels To Meet Your Requirements.

- Available Options -
- Varying Lengths & Heights
- Embedded Steel Plates Or Inserts
- Aluminum Access Hatches
- Cast Iron Frames & Covers
- Custom Opening Locations
- Design for Increased Loading Conditions
- Secondary Polypropylene Fiber Reinforcement

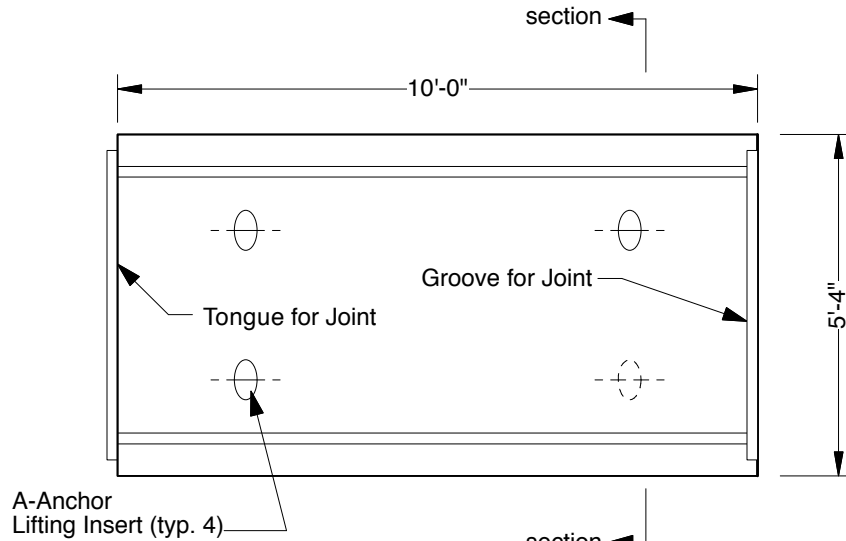

PLAN VIEW

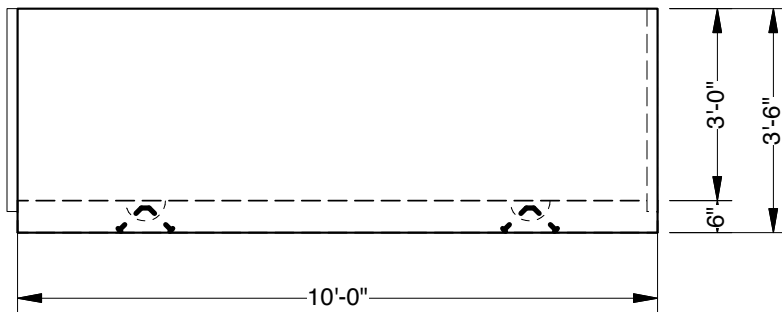
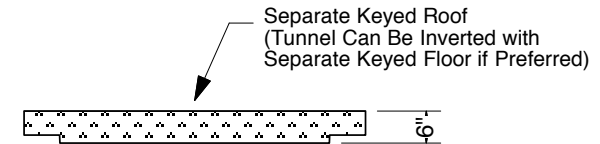

SIDE VIEW

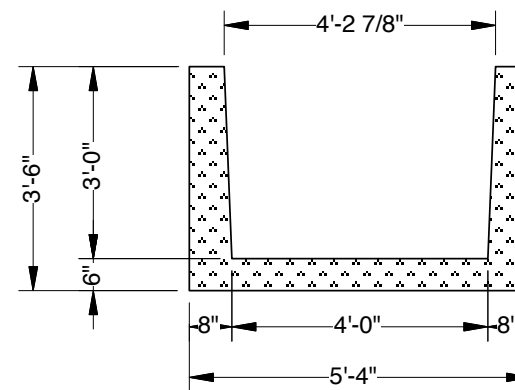

SECTION VIEW