

2375 Gallon Interceptor - 12' x 5' x 6'-6"

Advance Concrete Products Company



(800) 824-8351 (248) 887-4173 Fax: (248) 887-2755

All Concrete Shall Have A 28 Day Compressive Strength Of 4500 PSI.

Reinforcing Steel Shall Comply With ASTM A615 Grade 60 Rebar.
Bar Bending And Placement Shall Comply With The Latest ACI Standards.

Standard Structural Design Based On AASHTO HS 20 Wheel Loading.

1" Ø Butyl Rubber Rope Mastic Is Provided For Placement
Between Top And Bottom Sections Of Vault.

If Function Of Interceptor Is Oil, Gas, or Water Separation,
Fuel Resistant Rope Mastic Is Recommended & Can Be Provided.

- Available Options -
- Grade Adjustment Rings
- Cast Iron Frames & Covers
- Custom Opening Locations
- Watertight Boots in Variety of Sizes
- Double, Triple or Quadruple Compartments

Approximate Weight Total: ± 27,400 Lbs.
Bottom Section : ± 12,500 Lbs. Top Section: ± 12,500 Lbs.
Divider Wall: ± 2,400 Lbs.

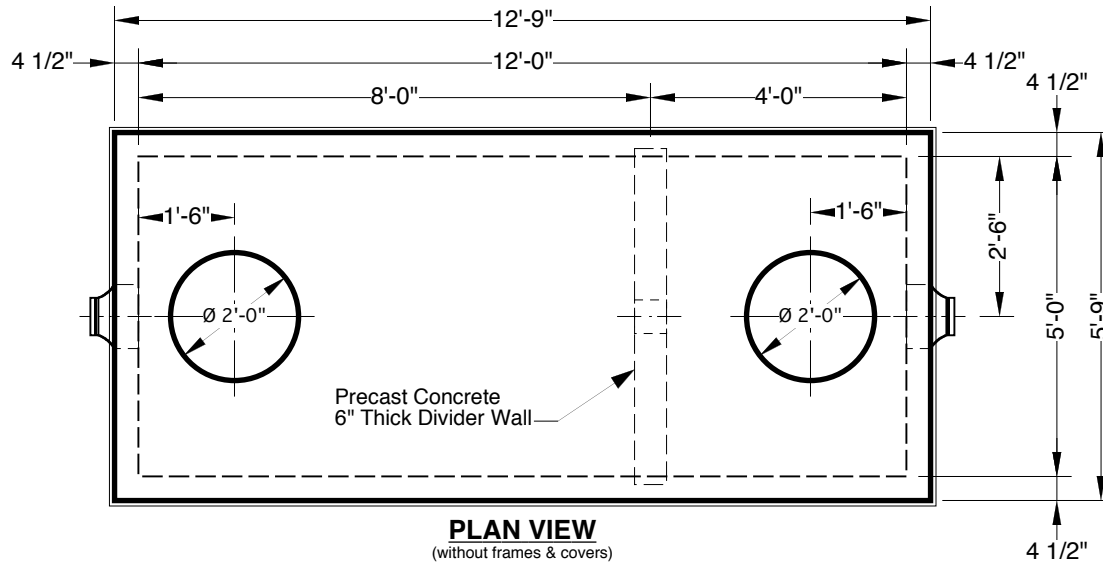

EJIW #1045 Heavy Duty, Bolt-Down
Gasketed Frame & Cover (typ. 2)

Watertight Boot Shown
for Ø6" PVC Outlet

